



**SPITZNAS**  
CUSTOMIZED POWER SOLUTIONS

# Hydraulic Vertical Grinder

**Type 1 2060 0010**

Underwater Tool



Illustration can differ from the original

## Repair Manual and Spare Parts List

Translation of the original manual,  
compiled: 01.12.16

# Repair

## Circuit diagram

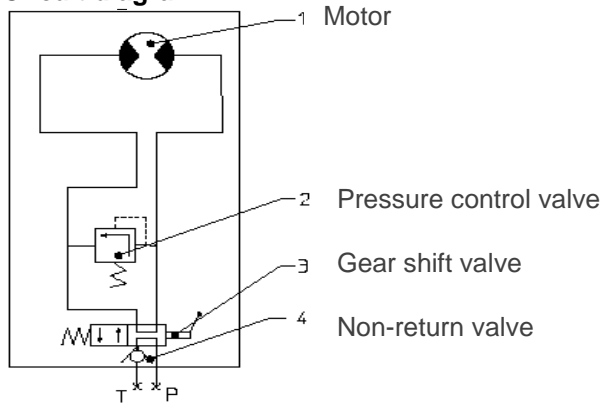

## General

Do not disassemble the tool until you know whether the problem is in one of the modules.

Then only disassemble the tool as necessary to repair as required.

Keep contaminants such as dirt and grit away from the internal parts at all times. Always identify and correct the cause of the problem prior to re-assembling.

Further wear and tool failure can result, if the original cause is not corrected.

Prior to separating the modules, determine exactly if the problem is in the hydraulic circuit or in one of the modules. The paragraph "Troubleshooting" of the operation manual contains helpful information for exact identification of the problem.

## Prior to disassembly

Clean outer surface of the machine.

Make sure that all new sealings are available for replacing the old ones during re-assembly.

Consider the installation direction of the sealings, before removing them. Install the new sealings at the same position as the old ones.

Notice: The installation direction of the parts mentioned in the following process instructions is indicated in the sectional drawings and parts list at the end of this instruction.

## Spare Parts

Only genuine spare parts may be used. There is no warranty for damages and liability is disclaimed, if non-original spare parts and accessories are used.

## Module

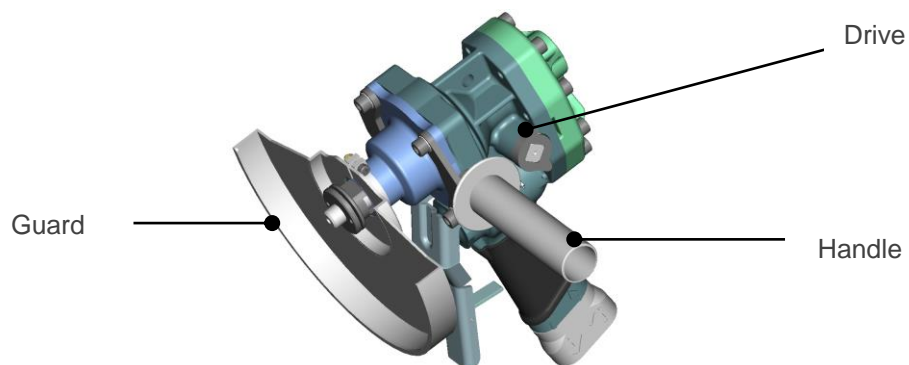

## Disassembly

### Preparation of the machine for disassembly

- Disconnect energy supply and secure against restart.
- Disconnect hydraulic hoses
- Remove tool from the tool holder and store it at a safe place.

### Disassembling modules of the machine

- Loosen tensioning flange item 28 (page 7) and take out tool.
- Screw out handle item 56 (page 7).
- Loosen 1 x hexagonal nut item 63 (page 7) and remove guard item 26.

### Disassembling the drive

- Loosen 8 x M8 socket head screws item 58 (page 8) and remove from motor housing item 1.
- Loosen 4 x M8 socket head screws item 58 (page 7) and remove output housing item 20 from motor housing item 1 (page 8).
- Take item 11, 12, 13 and 14 out of the motor cover item 7 (page 8).
- Remove feather key item 15 from the grinding shaft item 10 (page 7).
- Pull item 10, 18, 19, 22, 23 and 24 snap ring item 24 out of the motor housing item 1.
- Continue disassembling the drive, if necessary.
- After repairing the drive, a performance test is compulsory.

## Re-assembly

The re-assembly is done in reverse order.

Observe the following:

- Check O-rings, bearings and radial shaft sealing rings regarding damages and replace, if necessary.

If an assembling aid is used:

- Assembling aids must not cause damages.

All screws and nuts have to be tightened according to the instructions:

Tightening torques:			
Item	Description	Torque	Remark
30	Socket head screw M6	18 Nm	page 5
58	Socket head screw M8	27 Nm	page 6
59	Socket head screw M5	12 Nm	page 6
60	Hexagonal nut M5	12 Nm	page 6
61	Socket head screw M5	12 Nm	page 6
63	Hexagonal nut M5	12 Nm	page 6

### Assemble radial shaft sealing ring item 25:

Observe the following for proper functioning of the radial shaft sealing ring:

- The surface of the shaft has to be perfectly clean and undamaged.
- Prior to final installation of the radial shaft sealing ring the sliding surfaces have to be moistened with a drop of oil.

<b>Spare Parts List</b>					
Description:				Part and drawing number:	
<b>Hydraulic vertical grinder</b>				<b>1 2060 0010</b>	
Item.	Qty.	Description	Part and drawing no.		Remarks
1	1	Motor housing, assy.	6 1514 1940		
7	1	Motor cover, assy.	6 1514 1950		
9	1	Locking bushing	6 1512 1140		
10	1	Control bushing	1 2060 1040		
11	1	Gear pinion, assy.	6 1518 1920		
13	1	Gear pinion	1 2060 1020		
14	1	Running axle	6 1512 1130		
15	1	Feather key	9 1501 3580		
16	1	O-Ring	9 1921 5070	*	
17	1	Cylinder pin	9 1631 0420		
18	1	O-Ring	9 1921 5080	*	
19	1	Supporting ring	9 1919 0230	*	
20	1	Output housing	1 2060 7010		
21	1	O-Ring	9 1921 5070	*	
22	1	Snap ring	9 1703 0240		
23	1	Grooved ball bearing	9 1004 0380	*	
24	1	Snap ring	9 1702 0140		
25	1	Shaft sealing ring	9 1905 1740	*	
	1	Guard, assy.	1 2060 8000		Pos. 26 + Pos. 61 - 63
26	1	Guard	1 2060 8020		
27	1	Flange	1 2060 8030		
28	1	Wheel flange	1 2060 8050		
29	1	Connection block	1 2060 6660		
30	2	Socket head screw	9 1110 4530		
31	1	Threaded sleeve	1 2060 3120		
32	1	Pressure rod	1 2060 3110		
33	1	O-Ring	9 1921 5060	*	
34	1	O-Ring	9 1901 4100	*	
35	1	Control bushing	1 2060 3050		
36	1	Pressure spring	9 1803 4660		

<b>Spare Parts List</b>					
Description:				Part and drawing number:	
<b>Hydraulic vertical grinder</b>				<b>1 2060 0010</b>	
Item	Qty.	Description	Part and drawing no.		Remarks
	1	Valve lever, assy.	1 2060 3910		item 37 - 41
37	1	Valve lever	1 2060 3100		
38	1	Locking lever	1 2060 3200		
39	1	Tension sleeve	9 1630 1190		
40	1	Leg spring	9 1807 0300		
41	2	Bushing	1 2060 3220		
42	1	Rotary slide	6 1514 3320		
43	1	Seeger-Ring	9 1702 0810		
44	2	O-Ring	9 1921 6000	*	
45	2	Supporting ring	9 1919 0240	*	
46	1	Plate	1 2060 1090		
47	1	Tension sleeve	9 1630 1180		
48	2	Valve sleeve	6 1518 3510		
49	1	Circlip	9 1705 0010		
50	1	Washer	6 1518 3530		
51	2	O-Ring	9 1901 2750	*	
52	1	Valve slide	6 1518 3520		
53	1	Pressure spring	9 1803 5180		
54	2	O-Ring	9 1921 1190	*	
55	2	Handle angle	1 2060 6110		
56	1	Handle	2 1312 6010		
57	12	Locking washer	9 3329 0070		
58	12	Socket head screw	9 1110 5240		
59	1	Socket head screw	9 1110 3370		
60	1	Hexagonal nut	9 1209 0130		
61	1	Socket head screw	9 1110 3380		
62	1	Spring washer	9 3312 0250		
63	1	Hexagonal nut	9 1203 0330		
64	1	Scraper	9 1908 1970	*	
		Accessories:			
	1	Hose set	1 5080 9020		
	1	Multi oil spray	9 9902 0120		
	1	Socket wrench	9 1416 0080		
	1	Spanner AF 24	9 1301 0100		

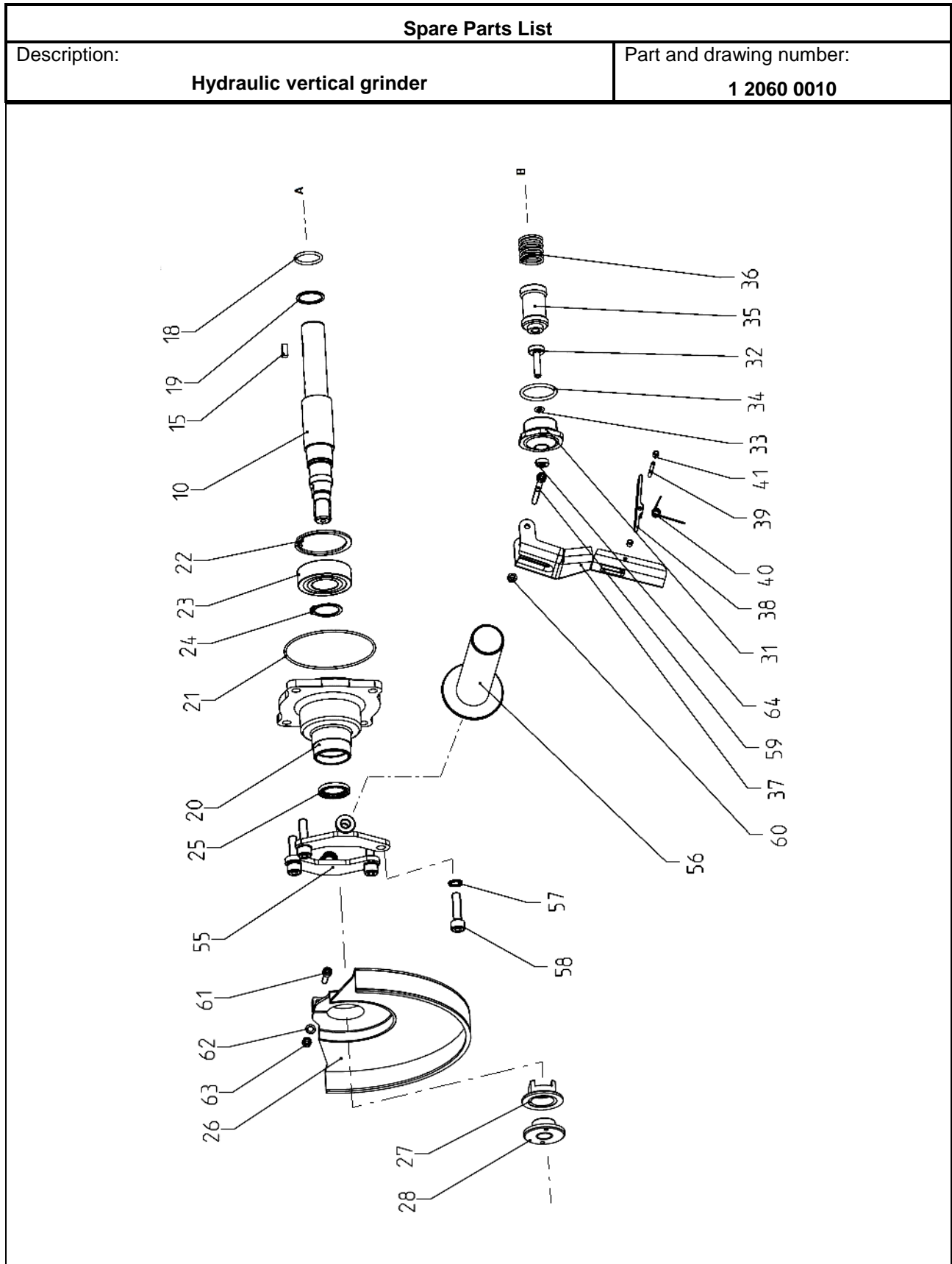

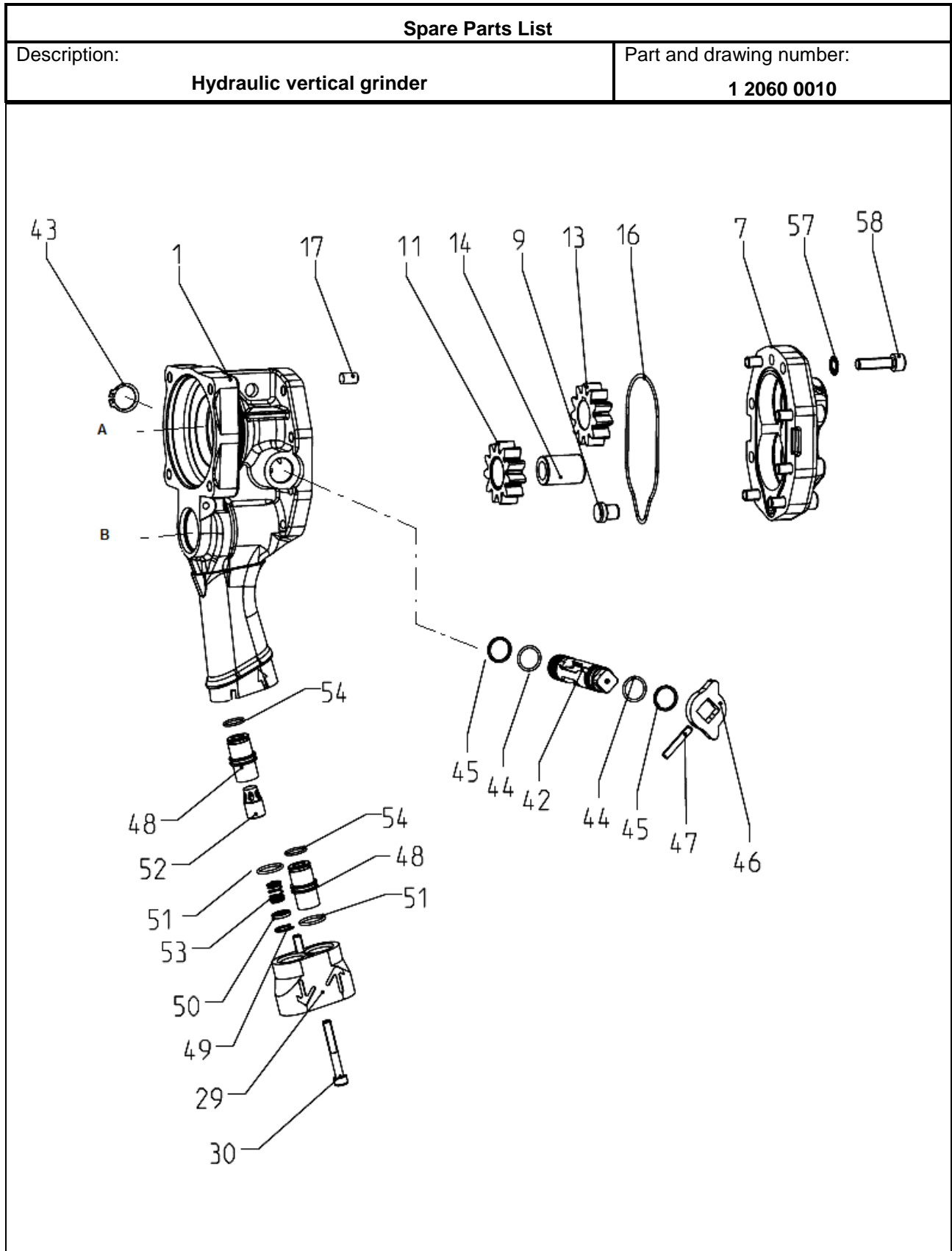



Maschinenfabrik GmbH  
Fellerstraße 4, 42555 Velbert  
Germany

Tel.: +49 2052 605 0  
Fax: +49 2052 605 29  
E-Mail: [spitznas@spitznas.de](mailto:spitznas@spitznas.de)  
[www.spitznas.de](http://www.spitznas.de)

Tools for the Specialist