

DM 280

Reservdelar

Spare parts

Ersatzteile

Pieces de rechange

Piezas de repuesto

Ricambi

Peças sobresselente

No.	Pos.	Description	No.	Pos.	Description
503 20 07-78	A1	SCREW	544 84 79-02	C	FRAME
502 30 44-01	B1	HOSE ASSY	544 84 80-01	C	COVER
502 47 97-01	A1	SHAFT	544 88 27-01	B1	BRACKET
502 49 61-01	A1	COMPRESSION SPRING	544 90 05-01	C	CABLE SLEEVE
502 49 63-02	A1	SEALING RING	720 12 76-06	A1	PARALLEL PIN
502 49 65-01	B1	O-RING	720 14 01-06	A1	PARALLEL PIN
502 49 65-02	A1	O-RING	723 22 85-81	B2	SCREW
502 49 70-01	A1	CIRCLIP	724 12 87-59	B1	SCREW
503 20 07-74	C	SCREW	724 12 91-01	B2	SCREW
503 20 07-78	B1	SCREW	725 54 51-01	A1	SCREW
503 20 07-82	C	SCREW	725 54 59-01	D	SCREW
503 21 88-30	B1C	SCREW	729 57 78-01	B2	SCREW
503 25 53-01	A1	NEEDLE BEARING	732 21 14-01	B2	LOCK NUT
503 26 60-03	B1	COUPLER	732 25 18-01	A1	LOCK NUT
503 26 60-04	B1	COUPLER	734 11 36-01	B1	WASHER
504 20 90-01	C	HOLDER ELECTRONICS	735 11 36-50	B2	SPRING WASHER
504 20 90-02	C	HOLDER ELECTRONICS	735 11 46-50	B2	SPRING WASHER
504 54 50-01	B2	FILTER	735 21 36-01	B1	LOCK WASHER
504 54 62-01	B2	TERMINAL BLOCK	735 31 22-41	A1	CIRCLIP
504 54 62-02	B2	TERMINAL BLOCK	735 31 25-00	A2	CIRCLIP
504 54 63-01	B2	CAPACITOR	735 31 30-00	A2	CIRCLIP
505 10 35-01	B1	O-RING	735 31 33-10	B1	CIRCLIP
505 15 50-01	B1	ROTOR	738 22 01-19	A2	BALL BEARING
505 15 51-01	B1	ROTOR	738 22 02-19	B1	BALL BEARING
505 40 60-01	A1	LABEL	738 22 04-19	A1	BALL BEARING
505 42 98-01	A1	LABEL	738 22 06-29	A2	BALL BEARING
505 44 33-02	C	CABLE	740 42 03-00	A1	O-RING
506 22 51-10	B2	STATOR ASSY			
506 22 51-20	B2	STATOR ASSY			
506 22 53-01	B2	SCREW			
506 22 58-02	B2	CARBON BRUSH			
506 95 70-01	C	JOINTING CABLE			
510 11 20-01	B1	NIPPLE KIT			
510 12 59-01	B1	HOSE KIT			
510 18 13-03	C	CABLE			
510 19 59-01	B1	VALVE KIT			
521 90 72-02	C	CABLE			
521 91 90-02	C	CABLE			
522 93 68-01	D	KIT, ADAPTER DS			
525 43 76-01	D	ALLEN KEY			
525 82 58-01	A1	SEAL KIT			
525 82 59-01	A2	GEAR WHEEL ASSY			
525 82 59-02	A2	GEAR WHEEL ASSY			
525 82 60-01	A2	OIL PIPE ASSY			
525 82 61-01	A2	KIT WEAR PARTS			
525 82 62-01	A2	SPINDLE SHAFT ASSY			
531 03 18-92	B2	BRUSH HOLDER			
531 07 38-91	C	SWITCH			
531 07 42-60	B1	FIBRE WASHER			
531 14 09-52	D	SPANNER 32			
531 14 09-58	A2	ADAPTER			
544 12 32-01	B2	CABLE CLAMP			
544 39 76-01	B1	SLEEVE			
544 39 77-01	A2	GEAR WHEEL SHAFT			
544 39 92-01	A2	GEAR WHEEL			
544 39 93-01	A2	GEAR WHEEL			
544 40 22-01	A1	GEAR HOUSING			
544 40 23-02	A1	COVER			
544 40 25-01	B1	COVER			
544 40 28-02	B2	COVER			
544 44 45-01	A2	SLIP CLUTCH ASSY			
544 44 49-02	B2	MOTOR HOUSING			
544 44 81-01	A1	GEAR SHIFT LEVER			
544 80 60-01	B1	AIR CONDUCTOR			
544 80 61-01	B2	AIR CONDUCTOR			
544 80 62-01	C	PROTECTIVE CAP			
544 80 63-01	C	PROTECTIVE CAP			
544 80 64-01	A1	MOTOR BRACKET			
544 80 66-01	A1	WEDGE			
544 80 67-01	A1	PLATE			

A1 DM280

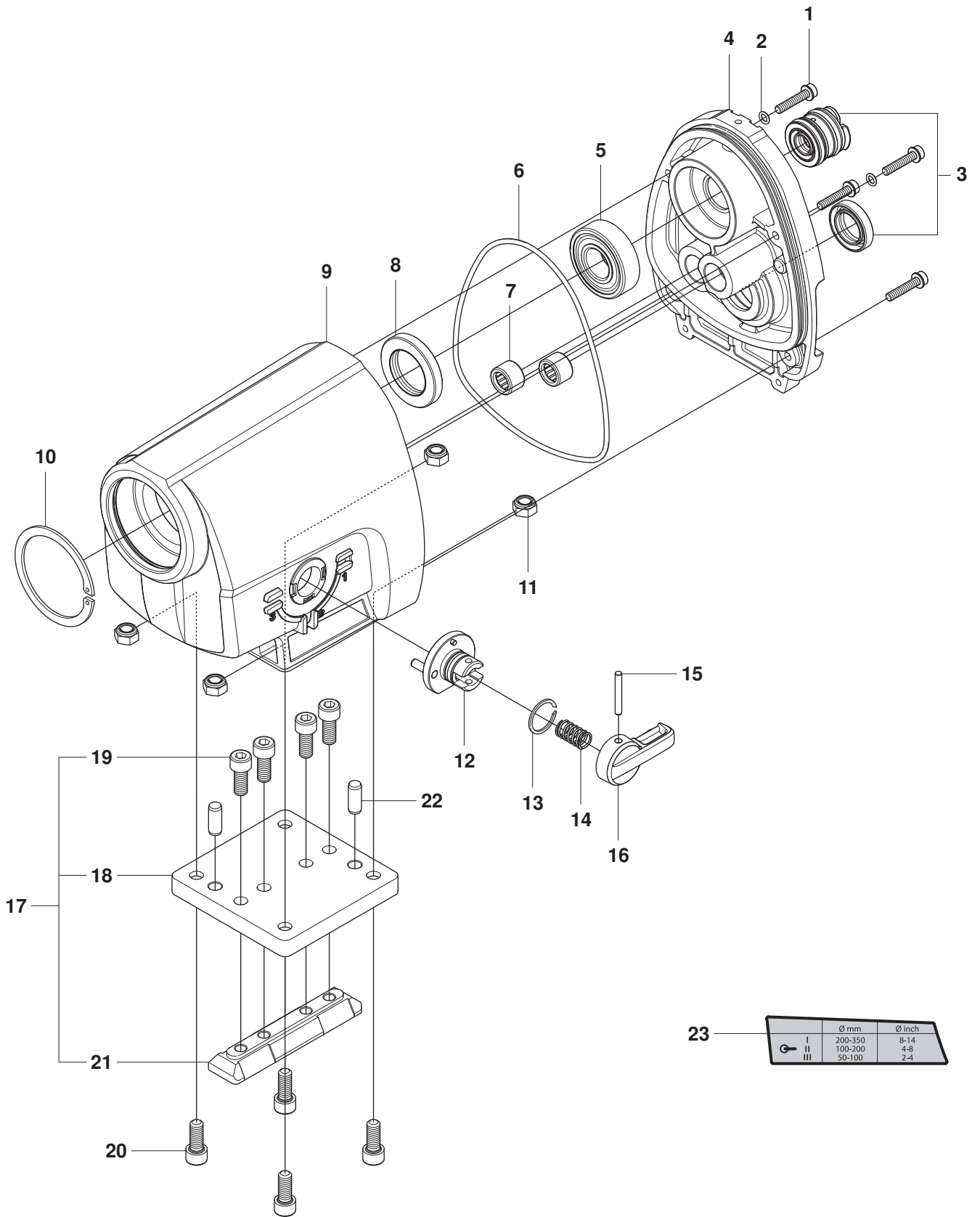

23

	Ø mm	Ø inch
I	200-350	8-14
II	100-200	4-8
III	50-100	2-4

Page A1
DM280

Pos.	Part No.	Description	Quantity	Notes	New Part
1	503 20 07-78	SCREW	4		
2	740 42 03-00	O-RING	2		
3	525 82 58-01	SEAL KIT	1		
4	544 40 23-02	COVER	1		
5	738 22 04-19	BALL BEARING	1		
6	502 49 65-02	O-RING	1		
7	503 25 53-01	NEEDLE BEARING	2		
8	502 49 63-02	SEALING RING	1		
9	544 40 22-01	GEAR HOUSING	1		
10	502 49 70-01	CIRCLIP	1		
11	732 25 18-01	LOCK NUT	4		
12	502 47 97-01	SHAFT	1		
13	735 31 22-41	CIRCLIP	1		
14	502 49 61-01	COMPRESSION SPRING	1		
15	720 12 76-06	PARALLEL PIN	1		
16	544 44 81-01	GEAR SHIFT LEVER	1		
17	544 80 64-01	MOTOR BRACKET	1	Incl. 18, 19, 21	
18	544 80 67-01	PLATE	1		
19	725 54 51-01	SCREW	4		
20	725 54 51-01	SCREW	4		
21	544 80 66-01	WEDGE	1		
22	720 14 01-06	PARALLEL PIN	2		
23	505 42 98-01	LABEL	1	Low speed version	
23	505 40 60-01	LABEL	1	High speed version	

A2 DM280

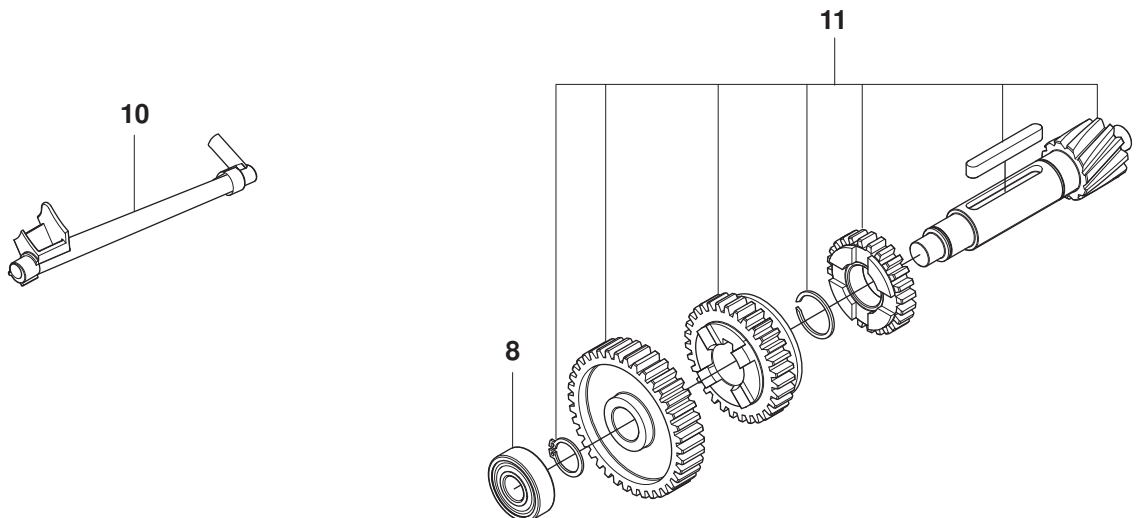
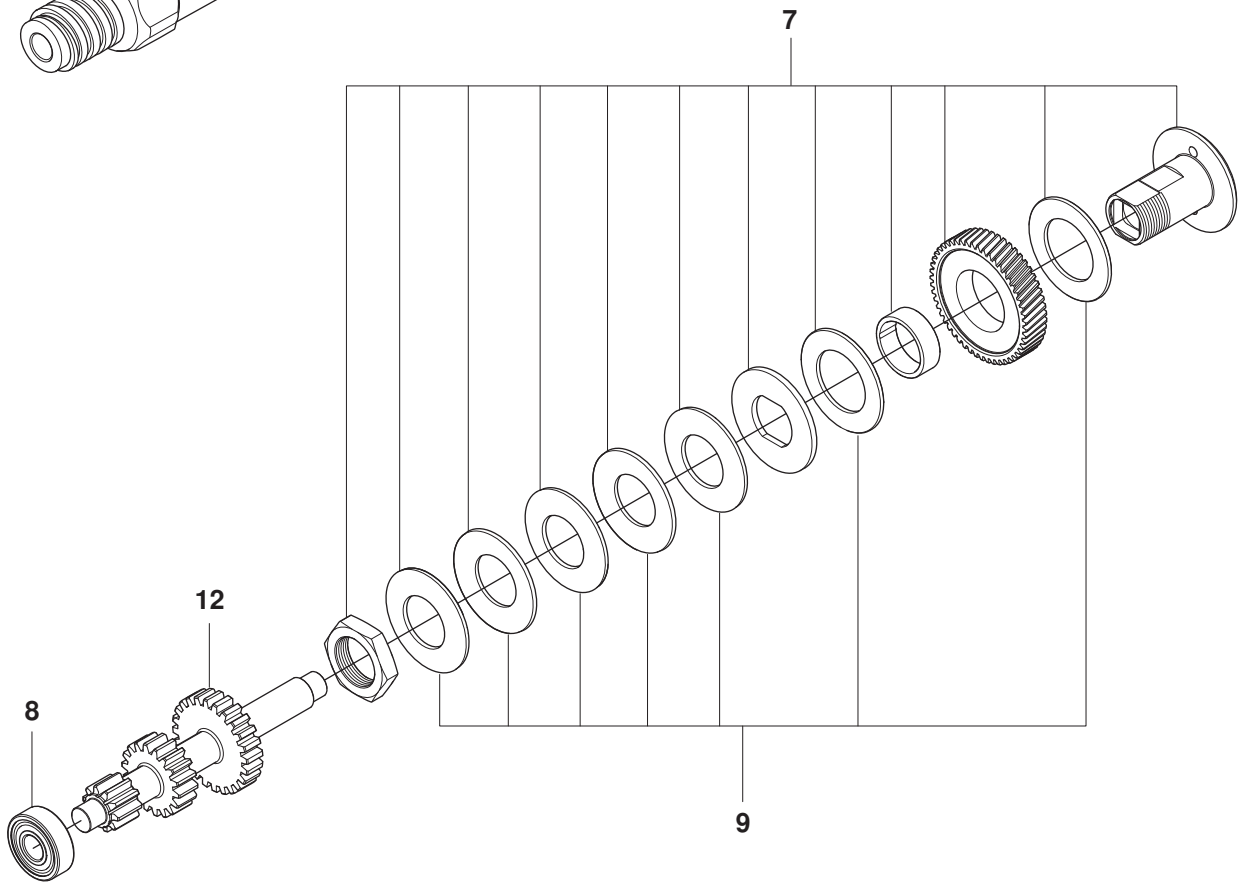
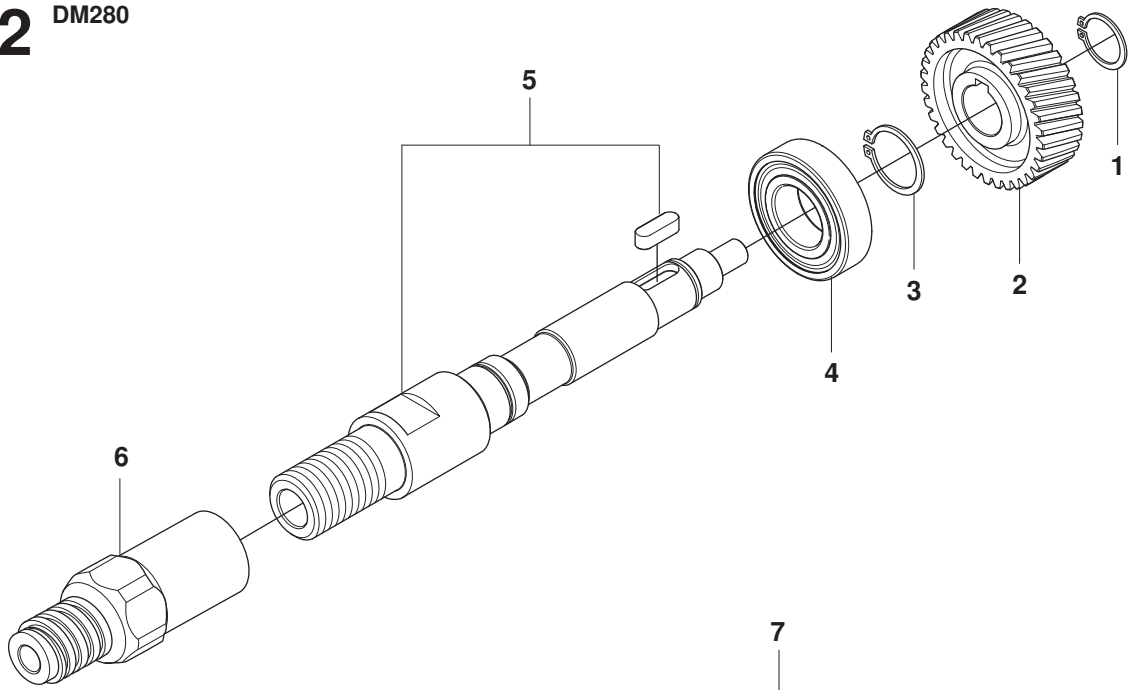

Pos.	Part No.	Description	Quantity	Notes	New Part
1	735 31 25-00	CIRCLIP	1		
2	544 39 92-01	GEAR WHEEL	1	Low speed version	
2	544 39 93-01	GEAR WHEEL	1	High speed version	
3	735 31 30-00	CIRCLIP	1		
4	738 22 06-29	BALL BEARING	1		
5	525 82 62-01	SPINDLE SHAFT ASSY	1		
6	531 14 09-58	ADAPTER	1	SE, FI, NO, DK	
7	544 44 45-01	SLIP CLUTCH ASSY	1		
8	738 22 01-19	BALL BEARING	2		
9	525 82 61-01	KIT WEAR PARTS	1		
10	525 82 60-01	OIL PIPE ASSY	1		
11	525 82 59-01	GEAR WHEEL ASSY	1	Low speed version	
11	525 82 59-02	GEAR WHEEL ASSY	1	High speed version	
12	544 39 77-01	GEAR WHEEL SHAFT	1		

B1 DM280

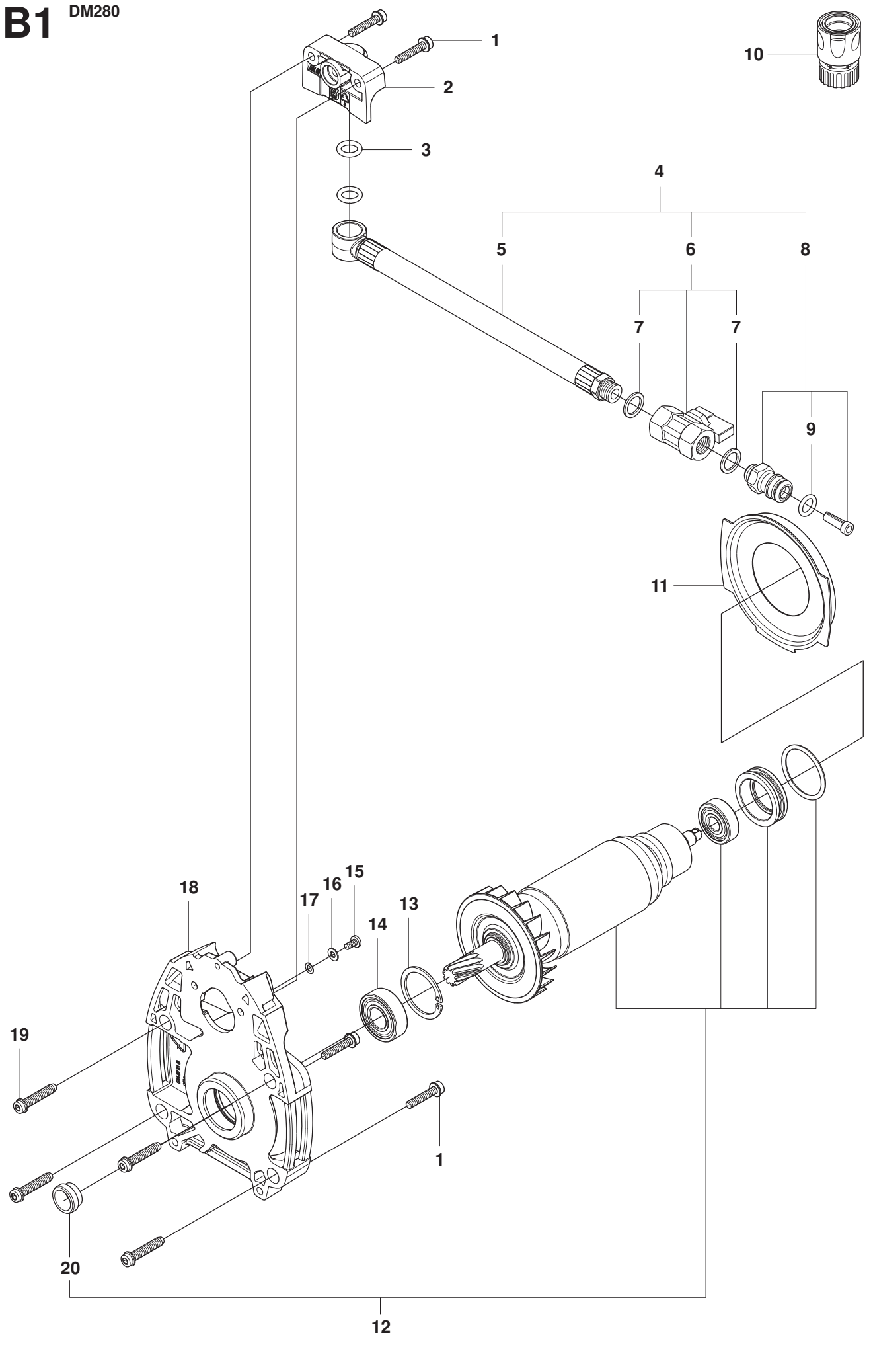

Page B1
DM280

Pos.	Part No.	Description	Quantity	Notes	New Part
1	503 20 07-78	SCREW	4		
2	544 88 27-01	BRACKET	1		
3	502 49 65-01	O-RING	2		
4	502 30 44-01	HOSE ASSY	1	Incl 5, 6, 8	
5	510 12 59-01	HOSE KIT	1		
6	510 19 59-01	VALVE KIT	1	Incl 7	
7	531 07 42-60	FIBRE WASHER	2		
8	510 11 20-01	NIPPLE KIT	1	Incl 9	
9	505 10 35-01	O-RING	1		
10	503 26 60-03	COUPLER	1	US, CANADA	
10	503 26 60-04	COUPLER	1		
11	544 80 60-01	AIR CONDUCTOR	1		
12	505 15 50-01	ROTOR	1	Incl 20 110V	
12	505 15 51-01	ROTOR	1	Incl 20 230V	
13	735 31 33-10	CIRCLIP	1		
14	738 22 02-19	BALL BEARING	1		
15	724 12 87-59	SCREW	1		
16	734 11 36-01	WASHER	1		
17	735 21 36-01	LOCK WASHER	1		
18	544 40 25-01	COVER	1		
19	503 21 88-30	SCREW	4		
20	544 39 76-01	SLEEVE	1		

B2 DM280

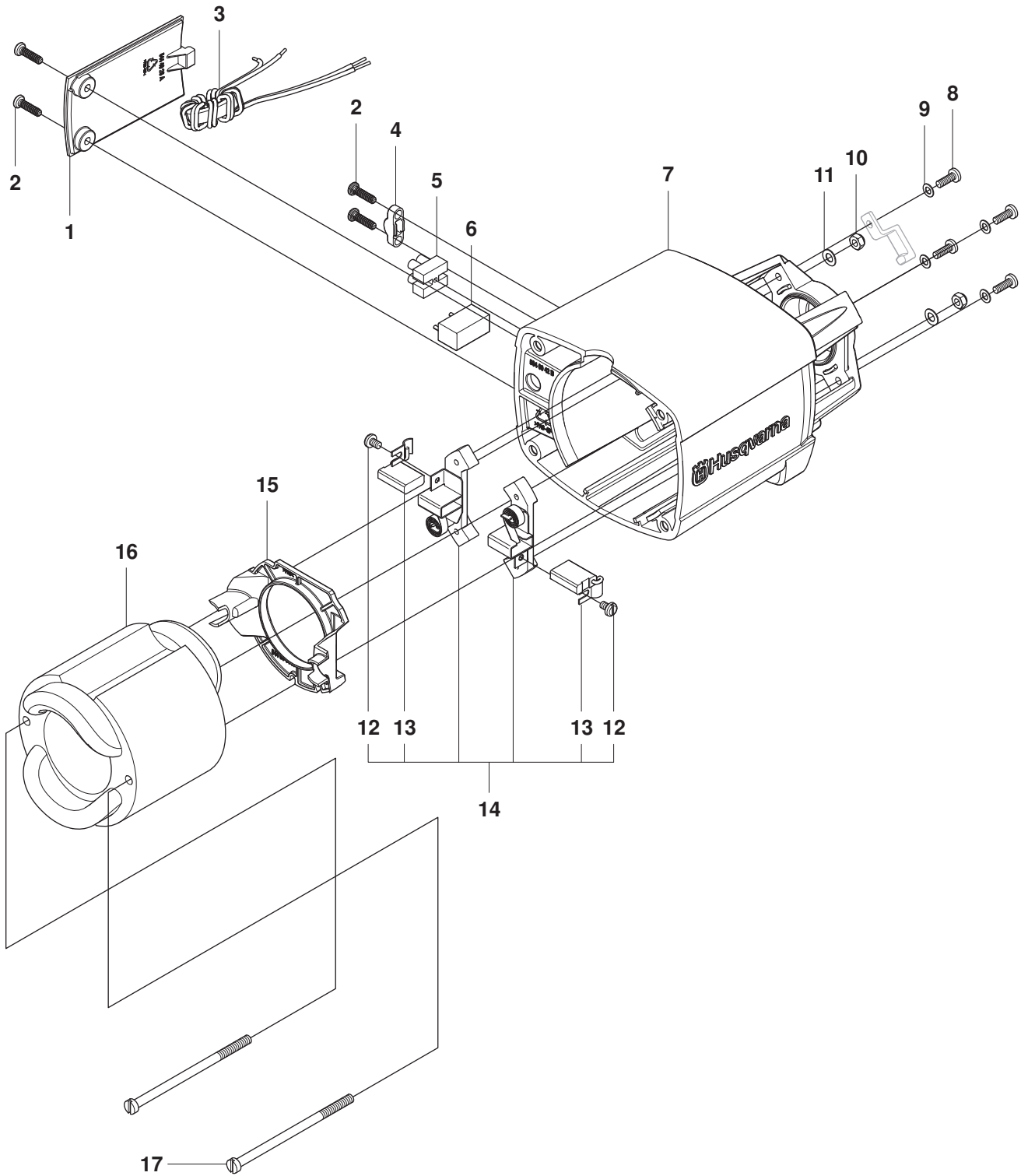

Page B2**DM280**

Pos.	Part No.	Description	Quantity	Notes	New Part
1	544 40 28-02	COVER	1		
2	729 57 78-01	SCREW	4		
3	504 54 50-01	FILTER	1	230V Only	
4	544 12 32-01	CABLE CLAMP	1		
5	504 54 62-01	TERMINAL BLOCK	1	110V	
5	504 54 62-02	TERMINAL BLOCK	1	230V	
6	504 54 63-01	CAPACITOR	1		
7	544 44 49-02	MOTOR HOUSING	1		
8	724 12 91-01	SCREW	4		
9	735 11 36-50	SPRING WASHER	4		
10	732 21 14-01	LOCK NUT	2		
11	735 11 46-50	SPRING WASHER	2		
12	723 22 85-81	SCREW	2		
13	506 22 58-02	CARBON BRUSH	2		
14	531 03 18-92	BRUSH HOLDER	2	Incl. 12 - 13	
15	544 80 61-01	AIR CONDUCTOR	1		
16	506 22 51-10	STATOR ASSY	1	110V	
16	506 22 51-20	STATOR ASSY	1	230V	
17	506 22 53-01	SCREW	2		

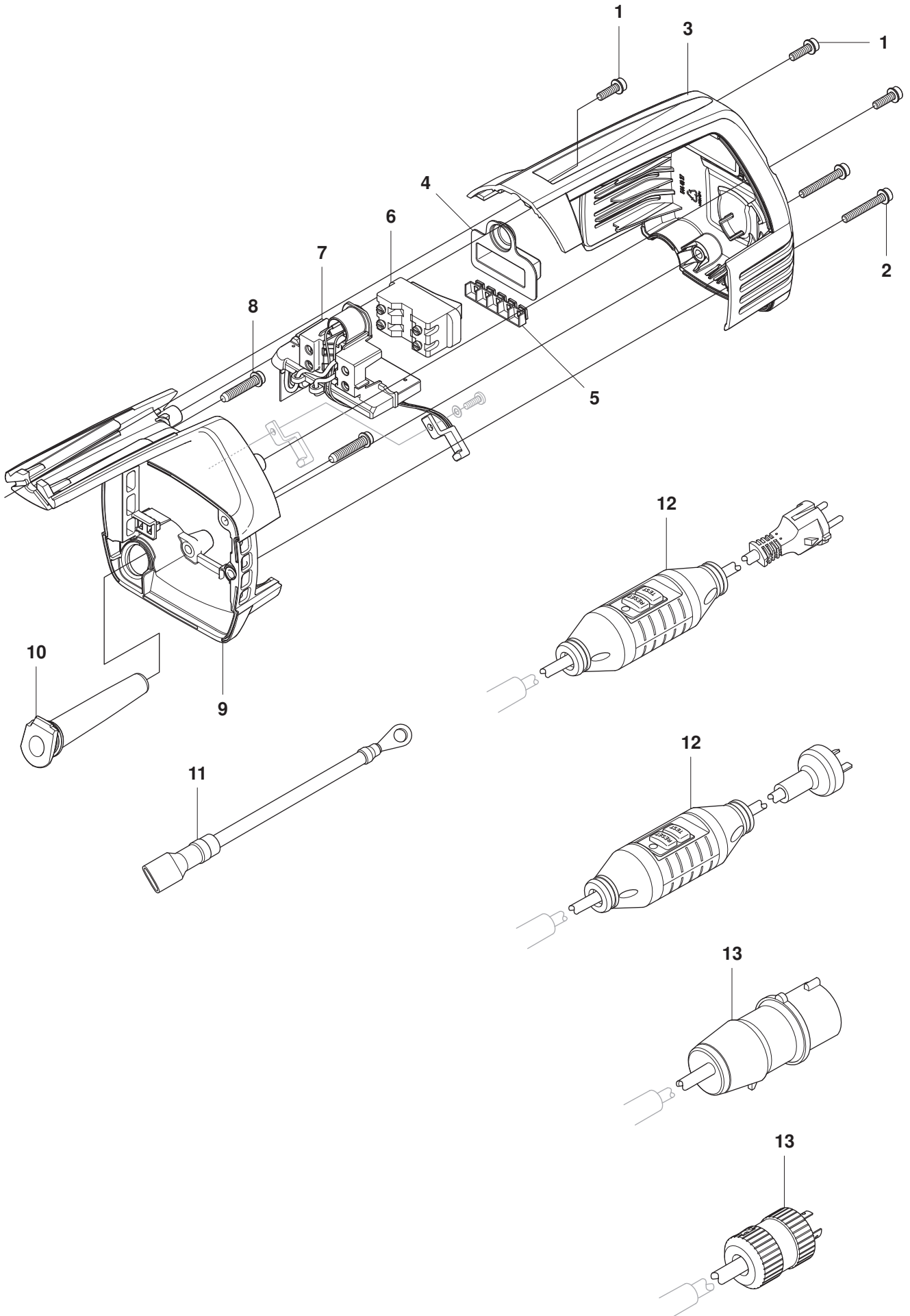

Page C
DM280

Pos.	Part No.	Description	Quantity	Notes	New Part
1	503 20 07-74	SCREW	3		
2	503 20 07-82	SCREW	2		
3	544 84 80-01	COVER	1		
4	544 80 62-01	PROTECTIVE CAP	1		
5	544 80 63-01	PROTECTIVE CAP	1		
6	531 07 38-91	SWITCH	1		
7	504 20 90-01	HOLDER ELECTRONICS	1	110V	
7	504 20 90-02	HOLDER ELECTRONICS	1	230V	
8	503 21 88-30	SCREW	2		
9	544 84 79-02	FRAME	1		
10	544 90 05-01	CABLE SLEEVE	1		
11	506 95 70-01	JOINTING CABLE	1	110V	
12	505 44 33-02	CABLE	1	230V incl PRCD 10mV, EU	
12	521 90 72-02	CABLE	1	230V incl PRCD 10mV, AU	
13	521 91 90-02	CABLE	1	110V UK	
13	510 18 13-03	CABLE	1	110V US	

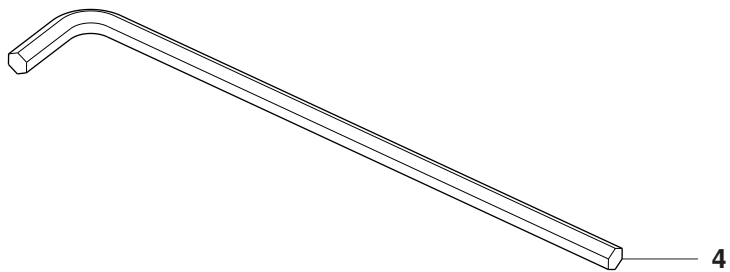
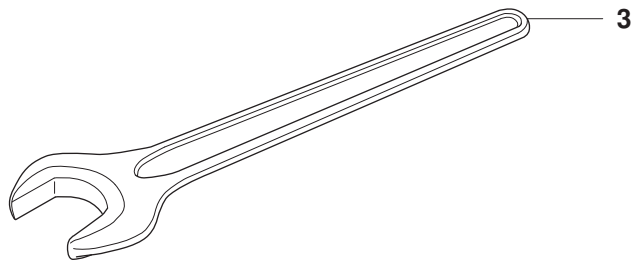
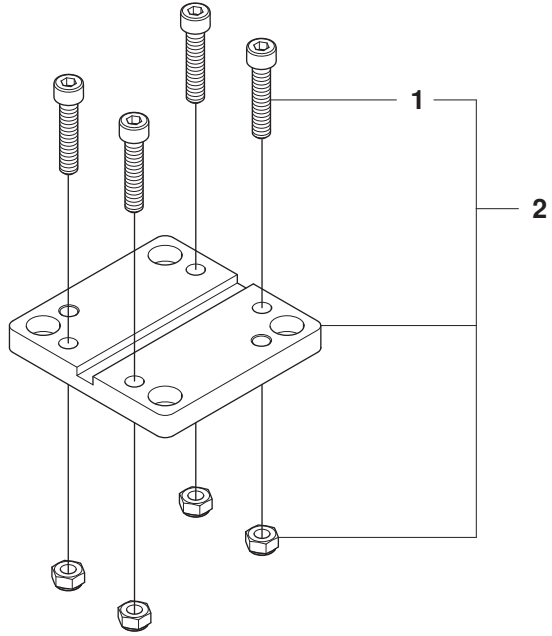

Page D
DM280

Pos.	Part No.	Description	Quantity	Notes	New Part
1	725 54 59-01	SCREW	4		
2	522 93 68-01	KIT, ADAPTER DS	1		
3	531 14 09-52	SPANNER 32	1	32mm	
4	525 43 76-01	ALLEN KEY	1		